

HELI



S SERIES

THREE WHEEL
1-2 ton
AC ELECTRIC FORKLIFT



Three Wheel
1-2 ton
AC ELECTRIC FORKLIFT

S SERIES

STANDARD EQUIPMENT

- ZF Drive unit includes Gearbox, AC-motor and oil-cooled disc brake
- ZAPI /CURTIS MOSFET electronic travel controllers and lifting controller
- High-mounted rear combination lights (back up, brake, turn signal)
- 3300mm STD 2-Stage mast
- Front lights (turn signal & clearance)
- Tilt cylinder(5 fwd/7 back)
- Side view mirror
- Carriage

- 2-section Control Valve
- DC/DC Converter
- Super-elastic tyre
- Battery
- Head lights
- Standard fork
- Load backrest

OPTIONS

- AC induction motor/AC controller hydraulic system
- Full free 2-Stage mast
- STD mast with other lifting height
- Full free 3-Stage mast
- Side-shifter(Hurg up,Integrated)
- Colored tyre (white/green)

- Nonstandard forks in length
- Other attachments
- Warning lights
- Battery charger
- Optional battery

ĐẠI LÝ CHÍNH HÃNG XE NÂNG HÀNG Heli

CÔNG TY TNHH XE NÂNG BÌNH MINH

HOTLINE: 097.790.3839

Email: hoangnguyen3888@gmail.com

Website: xenangheli.com

Trụ sở: Số 763, đường Nguyễn Văn Linh, P. Sài Đồng, Q. Long Biên, Hà Nội
 Chi nhánh: Khu phố Bình Đường 2, Phường An Bình, Thị xã Dĩ An, Bình Dương
 Chi nhánh: Số 288/2, Quốc lộ 1A, phường Thới An, quận 12, Hồ Chí Minh
 Chi nhánh: Số 1, đường Nguyễn Văn Linh, phường Hải Châu, Đà Nẵng

HELI

CHINESE EXPORT BRAND

Recommended
By China Chamber of Commerce for Import and Export of Machinery
And Electric Products

Newly designed wide-view mast



The newly designed wide-view mast enlarges operators' view effectively and lessens the blind area to provide a clearer vision.

↑ 14%
THE OPERATOR'S VISION INCREASES

Excellent steering system



The Steering system with new technologies not only provides a smoother swerve and faster positioning & steering, but also effectively lowers down the noise.

- ✓ Electronic differential
- ✓ New integrated load-sensing steering
- ✓ Double paralleled steering wheel
- ✓ Power Steering
- ✓ Turn around in situ
- ✓ Automatic slow-down device while steering

Dual AC drive motor

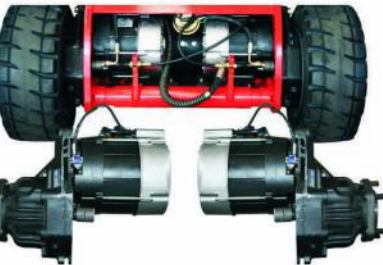

The powerful dual AC drive motors greatly enhance the performance of acceleration, driving, loading /unloading and grade ability.

↑ 11%
THE MAXIMUM DRIVING SPEED WITHOUT LOAD INCREASES

↑ 18%
THE MAXIMUM DRIVING SPEED WITH LOAD INCREASES

High efficiency loading/unloading performance

The innovative design and configuration of hydraulic system improve the working efficiency largely and provide a very efficient loading/unloading.

↑ 20%
THE MAXIMUM LIFTING SPEED WITHOUT LOAD INCREASES

↑ 12%
THE MAXIMUM LIFTING SPEED WITH LOAD INCREASES



- ✓ New low-speed & high-torque lifting motor
- ✓ MOSFET lifting controller
- ✓ New low-noise gear pump with differential tooth technology
- ✓ New dynamic load sensing technology in hydraulic system

Enough operation space

The new optimization layout widens the operator space for ensuring more comfortable and convenient operation.

↑ 13%
THE OPERATOR SPACE INCREASES



More intelligent performance

- ✓ AC traction controller
- ✓ Emergency power shut-down
- ✓ Controller self-protecting
- ✓ Standard CAN BUS
- ✓ Self-braking on ramp
- ✓ Preventing disordered operating
- ✓ Operator presence sensing system
- ✓ Speed selection function (normal/cutback)



ZAPI CONTROLLER



CURTIS CONTROLLER

Better Stability

As the front overhang reduces 10mm, and the center of truck gravity lowers 12%, the truck has a better stability

↓ 10mm
THE FRONT OVERHANG REDUCES

↓ 12%
THE CENTER OF TRUCK GRAVITY LOWERS





Manufacturers Data and Design Characteristics

Characteristics		HELI							
		CPD10S		CPD15S		CPD18S		CPD20S	
		CPQ1/CQ2	FQ1/FQ2	CPQ1/CQ2	FQ1/FQ2	CPQ1/CQ2	FQ1/FQ2	CPQ1/CQ2	FQ1/FQ2
1.01	Manufacturer's Name								
1.02	Model Designation								
1.03	Configuration Number								
1.04	Load Capacity	Q (kg)	1000	1500	1750	1750	1750	2000	2000
1.05	Load Center	c (mm)	500	500	500	500	500	500	500
1.06	Power Type	Battery		Battery		Battery		Battery	
1.07	Operator Type	Seated		Seated		Seated		Seated	
1.08	Wheelbase	y (mm)	1250	1250	1350	1455	1350	1455	1455
Wheels & Tyres									
2.01	Tyre Type	superelastic		superelastic		superelastic		superelastic	
2.02	Tyres Number (Front/Rear)	2/2		2/2		2/2		2/2	
2.03	Tread(centre of tyre),front	b10 (mm)	926	926	925	925	925	925	925
2.04	Tread(centre of tyre),rear	b11 (mm)	163	163	190	163	190	190	190
2.05	Tyre Size, Front	18×7-8		18×7-8		200/50-10		200/50-10	
2.06	Tyre Size, Rear	15×4.5-8		15×4.5-8		16×6-8		15×4.5-8	
Dimensions									
3.01	Load Distance	x (mm)	317	321	324	324	324	326	326
3.02	Mast Tilt Angle,F/R	a /β (°)	5/7	5/7	5/7	5/7	5/7	5/7	5/7
3.03	Height with Mast Lowered	h1(mm)	2220	2220	2220	2220	2220	2220	2220
3.04	Free Lift	h2(mm)	121	125	128	128	128	130	130
3.05	Standard Lift Height	h3(mm)	3300	3300	3300	3300	3300	3300	3300
3.06	Height with Mast Extended	h4(mm)	4330	4330	4330	4330	4330	4330	4330
3.07	Overhead Guard Height	h6(mm)	2080	1980	2080	1980	1980	1980	1980
3.08	Seat Height	h7(mm)	1000	910	1000	910	910	910	910
3.09	Fork Size	s/e/L(mm)	31×100×770		35×100×920		38×122×920		40×122×920
3.10	Fork Carriage to DIN 15173 A/B	2A		2A		2A		2A	
3.11	Length to fork face	L2(mm)	1779	1784	1783	1888	2016	1895	2016
3.12	Overall Width	b1(mm)	1070	1070	1070	1124	1124	1124	1124
3.13	Outside Turning Radius	Wa(mm)	1445	1445	1545	1660	1540	1660	1660
3.14	Ground Clearance at mast ,Loaded	m1(mm)	90	90	90	90	90	90	90
3.15	Ground Clearance at centre of wheelbase ,Loaded	m2(mm)	100	100	100	100	100	100	100
3.16	Right Stack Aisle width (Pallet size 1000x1000mm, clearance:200mm)	Ast(mm)	3075	3080	3180	3305	3185	3305	3305
3.17	Right Stack Aisle width (Pallet size 1200x1200mm, clearance:200mm)	Ast(mm)	3300	3300	3400	3530	3410	3530	3530
Performances									
4.01	Travel Speed,with/without load	km/h	14.2/15.4	14.5/15.5	14.2/15.4	14.5/15.5	14.2/15.5	14.2/15.4	14.0/15.3
4.02	Lifting Speed,with/without load	m/s	0.30/0.44		0.30/0.43		0.29/0.48		0.27/0.48
4.03	Lowering Speed	m/s	0.45		0.45		0.45		0.45
4.04	Gradient performance with load	%	27		24		22		20
4.05	Max. draw bar pull with load	N	11550		11920		15420		17390
4.06	Acceleration time (10 metres) W/O load	s	4.5/4.0		4.5/4.0		4.7/4.2		4.9/4.5
Weight									
5.01	Total Approximate Weight(W/O battery)	kg	2900/2161	2820/2260	3160/2421	3080/2372	3340/2590	3420/2480	3540/2600
5.02	Axle Loading*: Unloaded,Front/Rear	kg	1484/1416	1412/1408	1476/1648	1537/1543	1590/1750	1580/1650	1690/1850
5.03	Axle Loading*: Loaded,Front/Rear	kg	3173/727	3103/717	4006/654	4035/545	4525/645	4360/620	4920/700
Battery									
6.01	Battery Voltage/rated capacity(5h)	V/Ah	48/420	48/330	48/420	48/440	48/480	48/600	48/600
6.02	battery weight	kg	739(700-780)	560(532-588)	739(700-780)	708(673-743)	750(700-800)	940(900-1000)	940(900-1000)
6.03	Battery to DIN 43531/35/36/A/B/C		43531A	43531A	43531A	43531A	43531B	43531B	43531B
Motor & Controller									
7.01	Drive Motor - 60 Min. Rating	kW	2×4.5		2×4.5		2×4.5		2×4.5
7.02	Pump Motor - 15 Min. Rating	kW	7.5		7.5		8.6		10.5
7.03	Drive Motor Control Method		Mosfet/AC		Mosfet/AC		Mosfet/AC		Mosfet/AC
7.04	Pump Motor Control Method		Mosfet/DC		Mosfet/DC		Mosfet/DC		Mosfet/DC
7.05	Service Brake/Parking Brake		Hydraulic/Mechanical		Hydraulic/Mechanical		Hydraulic/Mechanical		Hydraulic/Mechanical
7.06	Relief Pressure	Mpa	14.5		14.5		17.5		17.5

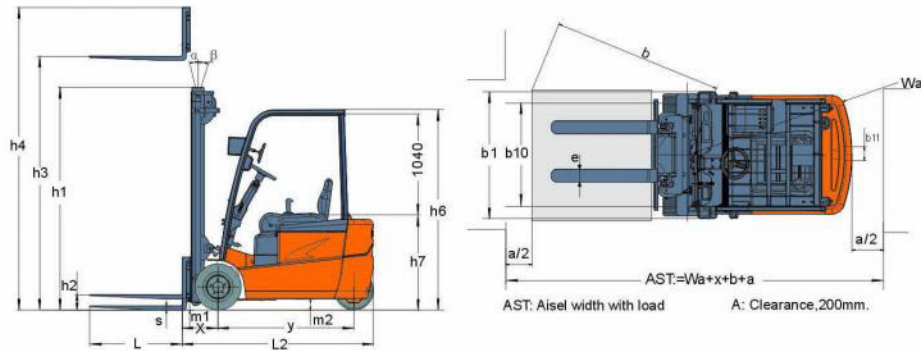

WIDE VIEW MAST

Mast model	Max. Lift height (mm)	Capacity at 500mm/load center				Height with mast lowered (mm) 1.0-2.0t	Tilting Angle (F/B)
		CPD10S	CPD15S	CPD18S	CPD20S		
M200	2000	1000	1500	1750	2000	1580	5/7
M250	2500	1000	1500	1750	2000	1830	5/7
M300	3000	1000	1500	1750	2000	2080	5/7
M330	3300	1000	1500	1750	2000	2220	5/7
M350	3500	1000	1500	1750	1950	2330	5/7
M370	3700	1000	1450	1750	1900	2430	5/7
M400	4000	1000	1400	1700	1850	2630	3/5
M425	4250	1000	1350	1650	1800	2755	3/5
M450	4500	1000	1300	1600	1750	2880	3/5
M500	5000	900	1200	1500	1650	3130	3/5
M550	5500	750	1000	1300	1400	3430	3/3
M600	6000	500	700	950	1100	3680	3/3

WIDE VIEW FULL FREE 2-STAGE MAST

Mast model	Max. Lift height (mm)	Capacity at 500mm/load center				Height with mast lowered (mm) 1.0-2.0t	Free lift (with Backrest) 1.0-2.0t	Tilting Angle (F/B)
		CPD10S	CPD15S	CPD18S	CPD20S			
ZM200	2000	1000	1500	1750	2000	1580	570	5/7
ZM250	2500	1000	1500	1750	2000	1830	820	5/7
ZM300	3000	1000	1500	1750	2000	2080	1070	5/7
ZM330	3300	1000	1500	1750	2000	2220	1210	5/7
ZM350	3500	1000	1450	1750	1950	2330	1320	5/7
ZM370	3700	1000	1400	1750	1900	2430	1420	5/7
ZM400	4000	1000	1350	1700	1850	2630	1620	3/5
ZM425	4250	1000	1300	1650	1800	2755	1745	3/5
ZM450	4500	1000	1300	1600	1750	2880	1870	3/5
ZM500	5000	900	1200	1500	1650	3130	2120	3/5
ZM550	5500	750	1000	1250	1400	3430	2420	3/3
ZM600	6000	500	650	900	1000	3680	2670	3/3

OTE: The free height of full free 2-stage mast without backrest increase +399mm

WIDE VIEW FULL FREE 3-STAGE MAST

Mast model	Max. Lift height (mm)	Capacity at 500mm/load center				Height with mast lowered (mm) 1.0-2.0t	Free lift (with Backrest) 1.0-2.0t	Tilting Angle (F/B)
		CPD10S	CPD15S	CPD18S	CPD20S			
ZSM360	3600	1000	1400	1750	1900	1770	760	3/5
ZSM400	4000	1000	1300	1700	1850	1905	895	3/5
ZSM435	4350	1000	1280	1650	1800	2020	1010	3/5
ZSM450	4500	1000	1250	1600	1750	2070	1060	3/5
ZSM470	4700	1000	1250	1600	1700	2140	1130	3/5
ZSM480	4800	1000	1200	1550	1650	2170	1160	3/5
ZSM500	5000	900	1100	1500	1600	2270	1260	3/5
ZSM540	5400	750	950	1200	1350	2405	1395	3/3
ZSM550	5500	700	900	1150	1300	2440	1430	3/3
ZSM600	6000	500	600	850	950	2620	1610	3/3
ZSM620	6200	350	500	750	850	2710	1700	3/3
ZSM650	6500	350	350	650	750	2810	1800	3/3

OTE: The free height of full free 3-stage mast without backrest increase
1.8-2t Free lifting height without bracket: +436mm
1-1.5t Free lifting height without bracket: +449mm

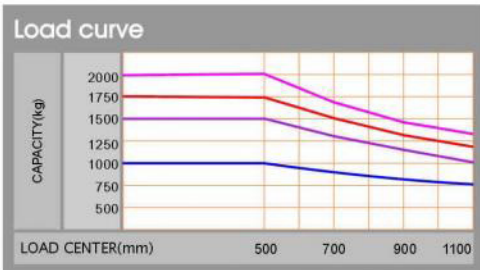

Vertical axle stands for load capacity while horizontal axle stands for load center. Load center is the distance counted from the front of the fork. The base point of the standard load is the center point of the cubic with the same 1000mm dimension in length, width and height. The load capacity should be down, if mast tilts forward, using non-standard forks or loading goods with extra width. Please notice the different load capacity between different load centers according to load chart.

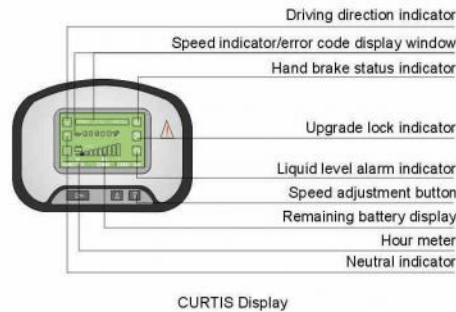
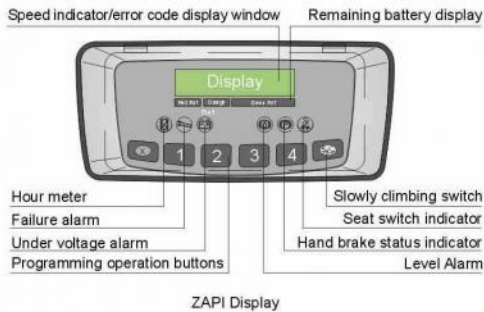

BATTERY COMPARTMENT SIZE				
MODEL	COMPARTMENT SIZE		Battery specifications	
	WD×LG×HT	SIZE	STANDARD	
CPD10/15S-CQ	845×433×789	835×418×784	DIN 43531A	
CPD10S-FQ	845×433×660	830×414×627	DIN 43531A	
CPD15S-FQ	845×533×660	830×522×627	DIN 43531A	
CPD18S-FQ	1040×460×660	1030×439×627	DIN 43531B	
CPD18/20S-CQ	1040×540×660	1030×529×627	DIN 43531B	



Renewable energy technologies

With the use of the excellent load-sensing steering system and AC controlling renewable energy technologies, the forklift is more energy-saving and the working hour of the battery is extended by 15%.

↑ 15%
THE PERFORMANCE OF BATTERY INCREASES